

PALLET LIFTERS

Standard Pallet Lifter (SPL90)

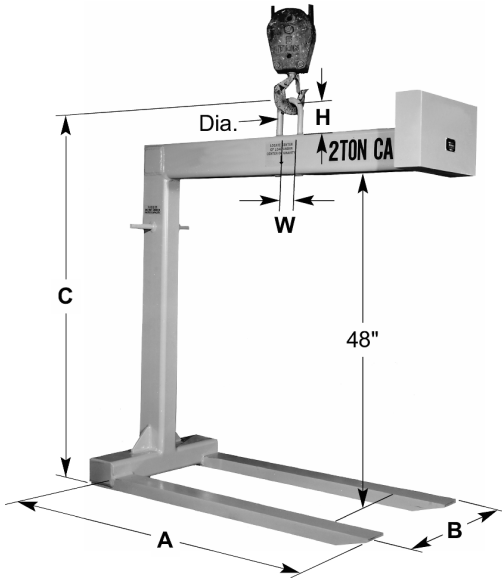

FEATURES

- Allows cranes to be used as a forklift truck.
- Counter balanced to hang level.
- No maintenance required.
- Great for pallet movement in areas not accessible to forklift trucks.

| Rated Cap. (Tons) | Part No. | Fork Length (A) (in.) | Fork Width (B) (in.) | Ea. Fork Width x Height (in.) | Bail Dimensions Dia. • W • H (in.) | Overall Height (C) (in.) | Wt. (lbs.) |
|-------------------|----------|-----------------------|----------------------|-------------------------------|------------------------------------|--------------------------|------------|
| 1 | SPL2x36 | 36 | 25 | 2 x 2 | Dia. • 1 | 57 1/2 | 292 |
| | SPL2x42 | 42 | 25 | 2 x 2 | W • 6 | 57 1/2 | 310 |
| | SPL2x48 | 48 | 25 | 2 x 2 | H • 5 | 58 1/2 | 371 |
| 1 1/2 | SPL3x36 | 36 | 25 | 3 x 2 | Dia. • 1 | 58 1/2 | 388 |
| | SPL3x42 | 42 | 25 | 3 x 2 | W • 6 | 58 1/2 | 432 |
| | SPL3x48 | 48 | 25 | 3 x 2 | H • 5 | 58 1/2 | 459 |
| 2 | SPL4x36 | 36 | 25 | 3 x 2 | Dia. • 1 | 59 1/2 | 448 |
| | SPL4x42 | 42 | 25 | 4 x 2 | W • 6 | 59 1/2 | 536 |
| | SPL4x48 | 48 | 25 | 4 x 2 | H • 5 | 59 1/2 | 627 |
| 3 | SPL6x42 | 42 | 25 | 4.5 x 2.5 | Dia. • 1.5 | 61 1/2 | 766 |
| | SPL6x48 | 48 | 27 | 4.5 x 2.5 | W • 6 1/8 H • 7 | 61 1/2 | 823 |

Wheeled Pallet Lifter (WPL93)

FEATURES

- Wheels allow unit to be moved without crane.
- Dual lift points eliminates need for counterweight.
- Light weight allows easy handling.

| Rated Cap. (Tons) | Part No. | Bail Dimensions Dia. • W • H (in.) | Overall Height (C) (in.) | Ea. Fork Width x Height (in.) | Wt. (lbs.) |
|-------------------|----------|------------------------------------|--------------------------|-------------------------------|------------|
| 1 | WPL2x48 | .5 • 2.5 • 3.75 | 60 | 2 x 2 | 245 |
| 2 | WPL4x48 | .75 • 2.75 • 4.5 | 62 | 4 x 2 | 405 |

