

LiftAlloy CHAIN SLING BASICS

Lift-All chain slings meet or exceed all OSHA, ASME B30.9 and NACM standards and regulations.

LiftAlloy chain slings, available in Grades 80 and 100, are recommended for rugged industrial applications in harsh environments where flexibility, abrasion resistance and long life are required. OSHA required annual inspections can be performed by Lift-All trained personnel.

Use of Chain Under Heat Conditions

When the chain itself is heated to temperatures shown below, the Working Load Limit (Rated Capacity) should be reduced as indicated.

Features, Advantages and Benefits

Promotes Safety

- Permanent steel capacity tag is serialized for identification
- Welded slings offer the security of tamper proof assemblies

Saves Money

- Alloy Steel construction assures long life
- Can be repaired, proof tested and recertified by Lift-All

Saves Time

- Easy to inspect for damage
- Stores easily

Temperature of Chain (°F)	Reduction of Working Load Limit While at Temperature		Permanent Reduction of Working Load Limit After Exposure to Temperature	
	Grade 80	Grade 100	Grade 80	Grade 100
Below -40	Do Not Use	Do Not Use	None	None
Below -20	None	Do Not Use	None	None
400	10%	15%	None	None
500	15%	25%	None	5%
600	20%	30%	5%	15%
700	30%	40%	10%	20%
800	40%	50%	15%	25%
900	50%	60%	20%	30%
1000	60%	70%	25%	35%
Over 1000	REMOVE FROM SERVICE			

Consult Lift-All about galvanized chain

Consult Lift-All about chain to be used in pickling operations

HOW TO ORDER CHAIN SLINGS

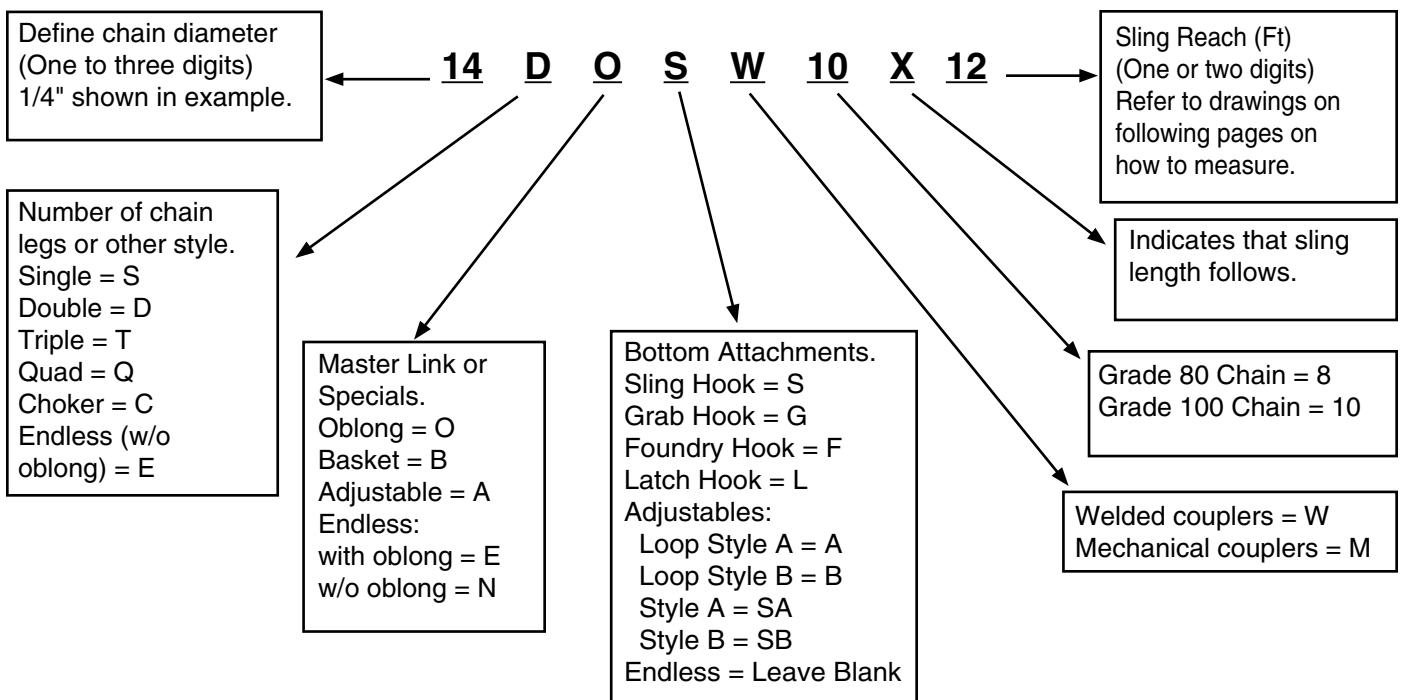

LiftAlloy CHAIN SLING BASICS

LiftAlloy Grade 80

- Proven reliability
- Available in welded or mechanically assembled slings
- Widest range of sizes and styles
- Greater temperature tolerance

LiftAlloy Grade 100

- Higher capacity per chain size can be used as an increased safety factor
- Higher capacity may allow use of smaller diameter chain for your lifts, reducing sling weight and cost
- Extreme abrasion resistance - more durable
- Shot blasted and oil finished chain for distinct, uniform appearance and corrosion resistance
- Power coated silver gray attachments for distinctive appearance, identification and corrosion resistance
- Meets or exceeds all OSHA, ASTM and NACM standards

Chain Wear Allowance

Determine wear by measuring cross section at link ends. If worn to less than the minimum thickness allowable, chain should be removed from service.

Chain Size (in.)	Minimum Allowable Thickness - A (in.)
7/8 (.218)	.189
9/32 (.281)	.239
3/8 (.375)	.342
1/2 (.500)	.443
5/8 (.625)	.546
3/4 (.750)	.687
7/8 (.875)	.750
1 (1.00)	.887
1 1/4 (1.250)	1.091

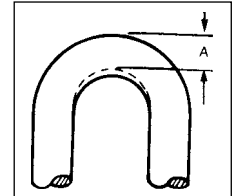

Minimum thickness based on OSHA recommendations.

Rated Capacity For LiftAlloy Chain Slings

Size of Chain		90°	60°	45°	30°	60°	45°	30°	Nominal Dimensions (in.)		Approx. No. of Links per ft.	Approx. Weight per 100 ft. (lbs.)
(in.)	(mm)	Single Chain @ 90° (lbs.)	Double Chain Slings *			Triple & Quad Chain Slings *			Inside Length	Inside Width		
Grade 80												
7/32	5.5	2,100	3,600	3,000	2,100	5,450	4,450	3,150	.671	.296	17.9	45
9/32	7.0	3,500	6,100	4,900	3,500	9,100	7,400	5,200	.868	.395	13.8	74
3/8	10.0	7,100	12,300	10,000	7,100	18,400	15,100	10,600	1.222	.572	9.8	146
1/2	13.0	12,000	20,800	17,000	12,000	31,200	25,500	18,000	1.404	.720	8.5	258
5/8	16.0	18,100	31,300	25,600	18,100	47,000	38,400	27,100	1.733	.854	6.9	387
3/4	20.0	28,300	49,000	40,000	28,300	73,500	60,000	42,400	2.160	1.052	5.5	622
7/8	22.0	34,200	59,200	48,400	34,200	88,900	72,500	51,300	2.250	1.137	5.3	776
1	26.0	47,700	82,600	67,400	47,700	123,900	101,200	71,500	2.664	1.348	4.5	995
1 1/4	32.0	72,300	125,200	102,200	72,300	187,800	153,400	108,400	3.250	1.656	3.7	1,571
Grade 100												
7/32	5.5	2,700	4,700	3,800	2,700	7,000	5,700	4,000	.670	.284	17.9	45
9/32	7.0	4,300	7,400	6,100	4,300	11,200	9,100	6,400	.868	.380	13.8	73
3/8	10.0	8,800	15,200	12,400	8,800	22,900	18,700	13,200	1.181	.512	9.8	148
1/2	13.0	15,000	26,000	21,200	15,000	39,000	31,800	22,500	1.535	.688	8.5	255
5/8	16.0	22,600	39,100	32,000	22,600	58,700	47,900	33,900	1.890	.819	6.9	383
3/4	20.0	35,300	61,100	49,900	35,300	91,700	74,900	53,000	2.362	1.024	5.5	625

* **WARNING** Do not exceed rated capacities. Sling capacity decreases as the angle from horizontal decreases. Slings should not be used at angles of less than 30°. Refer to chain chart this page and Effect of Angle chart page 10.

** A quad branch chain four branches. and used with branches at same angle of inclination.

INSPECTION CRITERIA FOR CHAIN

All slings should be inspected for damage prior to each use to assure that their strength has not been compromised. The following photos illustrate some of the common damage that occurs to indicate that the sling must be taken out of service.

THE DAMAGE: Stretched Chain Links - Indicates the sling has been extremely overloaded or subjected to shock loading.

WHAT TO LOOK FOR: Lengthening of the links and narrowing of the link width. Links that do not hinge freely with adjacent links are stretched and must be taken out of service, however, stretch **can** occur without this indicator.

TO PREVENT: Avoid overloading and shock loading.

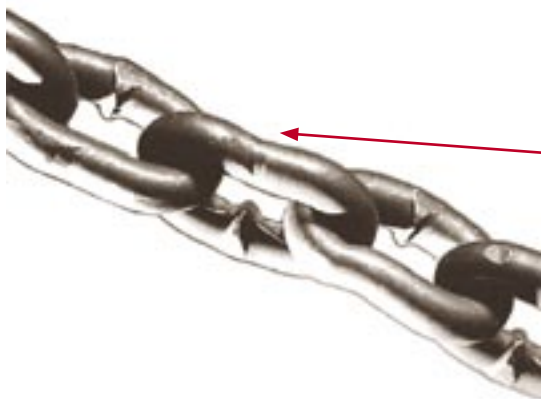

THE DAMAGE: Bent Links

WHAT TO LOOK FOR: Bending usually occurs in only one or two adjacent links. Links will have an irregular shape when compared to other links.

TO PREVENT: Bent links are usually the result of the chain going around the sharp edge of a load during a lift. Load edges must be padded to protect both chain and load.

THE DAMAGE: Weld Spatter

WHAT TO LOOK FOR: Metallic bumps on any link of chain.

TO PREVENT: The heat from weld spatter can adversely affect the strength of a chain link. Slings must be shielded from welding operations.

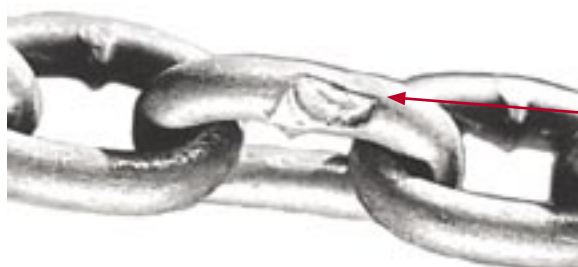

THE DAMAGE: Gouged Links

WHAT TO LOOK FOR: Indentations on an otherwise smooth link surface.

TO PREVENT: Gouging of links is usually caused by heavy loads being dragged over or dropped onto the chain. Protect sling from these situations.

INSPECTION CRITERIA FOR CHAIN

THE DAMAGE: **Heat**

WHAT TO LOOK FOR: Discolored areas of chain

TO PREVENT: High temperatures begin to affect alloy chain strength at 400°F. When using chain slings at elevated temperatures, refer to the Lift-All temperature chart for chain slings for working load reductions.

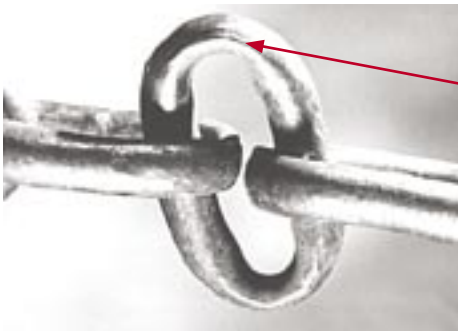

THE DAMAGE: **Worn Links**

WHAT TO LOOK FOR: Excessive wear and a reduction of the material diameter, especially at the bearing points. Refer to Lift-All Wear Allowance Table for minimum allowable link thickness.

TO PREVENT: Wear is a natural result of sling use. Keeping load weights within the ratings of the slings being used will give the maximum sling wear life.

LiftAlloy
Chain

THE DAMAGE: **Bent/Worn/Cracked Hardware**

WHAT TO LOOK FOR: Wear of hooks and other fittings usually occurs at the bearing points. Hooks bent more than 10° from the plane of the unbent hook. Hooks opened more than 15% of the normal throat opening.

TO PREVENT: Never point load hooks or lift with hardware on a load edge.



LiftAlloy SINGLE CHAIN SLINGS

Chain Size (in.)	'Rated Capacity* Vertical (lbs.)		Approx. Weight 5 foot Reach Type SOS (lbs.)
	Grade 80	Grade 100	
7/32	2,100	2,700	4
9/32	3,500	4,300	5
3/8	7,100	8,800	10
1/2	12,000	15,000	18
5/8	18,100	22,600	27
3/4	28,300	35,300	44
7/8	34,200	-	58
1	47,700	-	79
1 1/4	72,300	-	121

Note: 1. Also referred to as "Working Load Limit".

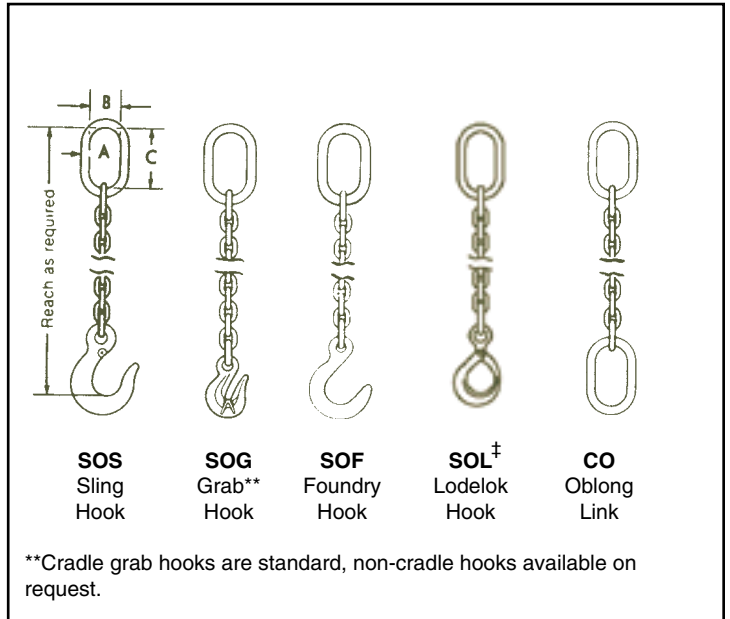

LiftAlloy DOUBLE CHAIN SLINGS

Chain Size (in.)	'Rated Capacity* @ 60° (lbs.)		Approx. Weight 5 foot Reach Type DOS (lbs.)
	Grade 80	Grade 100	
7/32	3,600	4,700	8
9/32	6,100	7,400	10
3/8	12,300	15,200	17
1/2	20,800	26,000	32
5/8	31,300	39,100	51
3/4	49,000	61,100	74
7/8	59,200	-	99
1	82,600	-	134
1 1/4	125,200	-	211

Note: 1. Also referred to as "Working Load Limit".

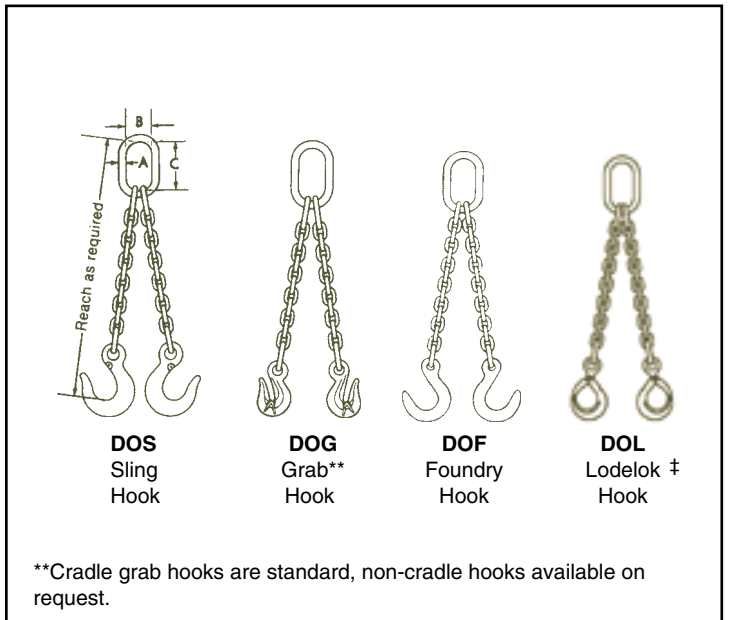

* **WARNING** Do not exceed rated capacities. Sling capacity decreases as the angle from horizontal decreases. Slings should not be used at angles of less than 30°. Refer to chain chart page 85 and Effect of Angle chart page 10.

† Not available in Grade 100.

LiftAlloy TRIPLE AND QUAD CHAIN SLINGS

Chain Size (in.)	¹Rated Capacity* @ 60° (lbs.)		Approx. Weight 5 foot Reach Type TOS (lbs.)	Approx. Weight 5 foot Reach Type QOS (lbs.)
	Grade 80	Grade 100		
7/32	5,450	7,000	12	16
9/32	9,100	11,200	16	19
3/8	18,400	22,900	28	36
1/2	31,200	39,000	53	63
5/8	47,000	58,700	81	100
3/4	73,500	91,700	116	140
7/8	88,900	-	154	187
1	123,900	-	209	250
1 1/4	187,800	-	358	406

Note: 1. Also referred to as "Working Load Limit".

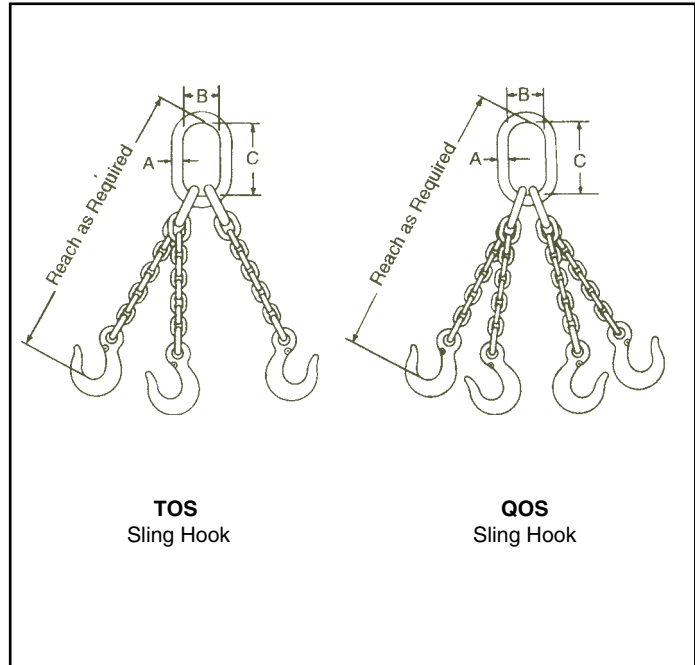

TOS
Sling Hook

QOS
Sling Hook

LiftAlloy Chain

LiftAlloy BASKET TYPE CHAIN SLINGS

Chain Size (in.)	¹Rated Capacity* @ 60° (lbs.)			
	Single		Double	
	Grade 80	Grade 100	Grade 80	Grade 100
7/32	3,600	4,700	5,450	7,000
9/32	6,100	7,400	9,100	11,200
3/8	12,300	15,200	18,400	22,900
1/2	20,800	26,000	31,200	39,000
5/8	31,300	39,100	47,000	58,700
3/4	49,000	61,100	73,500	91,700
7/8	59,200	-	88,900	-
1	82,600	-	123,900	-
1 1/4	125,200	-	187,800	-

Note: 1. Also referred to as "Working Load Limit".

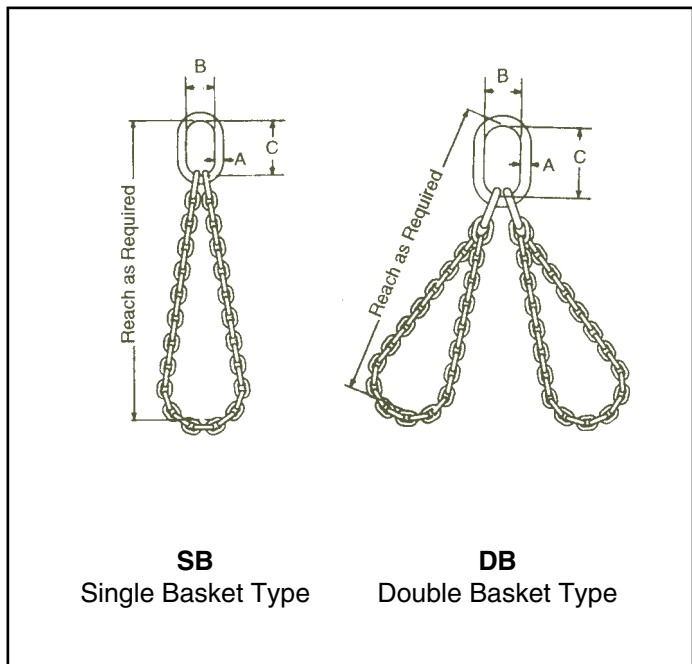

SB
Single Basket Type

DB
Double Basket Type



Do not exceed rated capacities. Sling capacity decreases as the angle from horizontal decreases. Slings should not be used at angles of less than 30°. Refer to chain chart page 85 and Effect of Angle chart page 10.

LiftAlloy ADJUSTABLE CHAIN SLINGS (Traditional Styles)

LiftAlloy Adjustable Loop Chain Slings

Chain Size (in.)	'Rated Capacity*' @ 60° (lbs.)			
	Single		Double	
	Grade 80	Grade 100	Grade 80	Grade 100
7/32	3,600	4,700	5,450	7,000
9/32	6,100	7,400	9,100	11,200
3/8	12,300	15,200	18,400	22,900
1/2	20,800	26,000	31,200	39,400
5/8	31,300	39,100	47,000	58,700
3/4	49,000	61,100	73,500	91,700
7/8	59,200	-	88,900	-
1	82,600	-	123,900	-
1 1/4	125,200	-	187,800	-

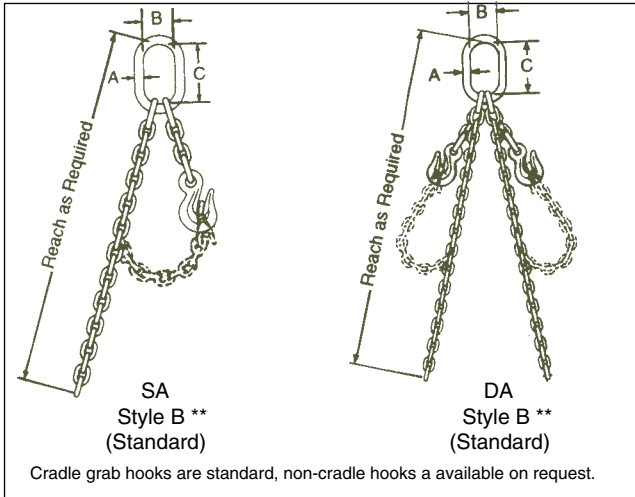

Slings shown here are the most popular of the traditional adjustable type slings. However, *Lift-All's* engineering staff can design whatever configuration is required to fit individual needs.

** Style B, single and double adjustable slings are furnished with approximately one (1) foot of chain in short branches unless otherwise specified in the order. Style A, hook is attached to master link with a coupling link.

LiftAlloy Adjustable Chain Slings

Chain Size (in.)	'Rated Capacity*' (lbs.)			
	Single at 90°		Double at 60°	
	Grade 80	Grade 100	Grade 80	Grade 100
7/32	2,100	2,700	3,600	4,700
9/32	3,500	4,300	6,100	7,400
3/8	7,100	8,800	12,300	15,200
1/2	12,000	15,000	20,800	26,000
5/8	18,100	22,600	31,300	39,100
3/4	28,300	35,300	49,000	61,100
7/8	34,200	-	59,200	-
1	47,700	-	82,600	-
1 1/4	72,300	-	125,200	-

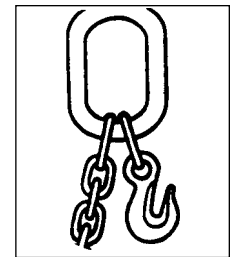
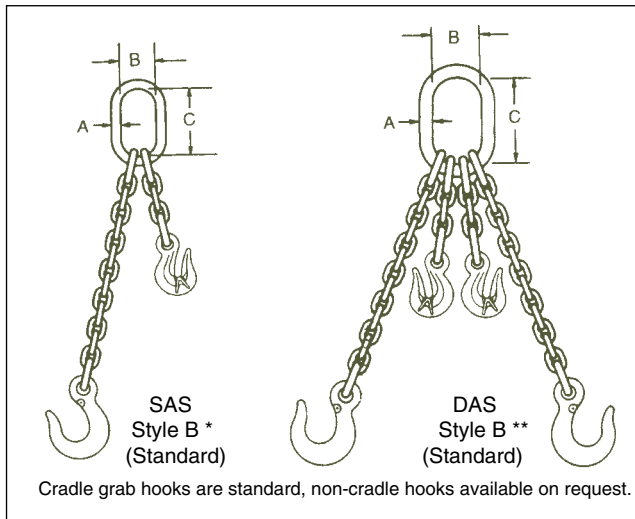

LiftAlloy ENDLESS BASKET CHAIN SLINGS

Chain Size (in.)	'Rated Capacity*' (lbs.)			
	Single at 90°		Double at 60°	
	Grade 80	Grade 100	Grade 80	Grade 100
7/32	2,100	2,700	3,600	4,700
9/32	3,500	4,300	6,100	7,400
3/8	7,100	8,800	12,300	15,200
1/2	12,000	15,000	20,800	26,000
5/8	18,100	22,600	31,300	39,100
3/4	28,300	35,300	49,000	61,100
7/8	34,200	-	59,200	-
1	47,700	-	82,600	-
1 1/4	72,300	-	125,200	-

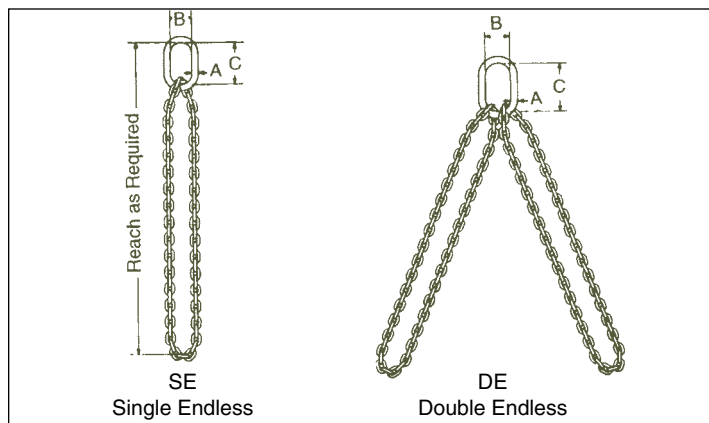

Note: 1. Also referred to as "Working Load Limit".



WARNING

Do not exceed rated capacities. Sling capacity decreases as the angle from horizontal decreases. Slings should not be used at angles of less than 30°. Refer to chain chart page 85 and Effect of Angle chart page 10.

ADJUST-A-LINK GRADE 100 CHAIN SLINGS

(Patent No. 4941698)

The most easily adjustable and versatile chain sling is now stronger, too!
Ideal for machine shop and maintenance departments varied requirements.

**New, Improved
Master Control
Plate ***

Features, Advantages and Benefits

Promotes Safety

- Chain cannot be removed from the master control plate, assuring the capacity rating will not be compromised
- Alloy steel master control link for strength and reliability
- Each assembly serialized for traceability
- Complies with OSHA - proof tested and certified

Saves Money

- Grade 100 chain provides approximately 25% higher capacities than our previous *Adjust-A-Links* - replaces larger, more expensive slings
- New angled plate design reduces bending torque on chain and plate - reduces wear and extends sling life
- Wider top bearing surface reduces wear to both plate and crane hook
- Versatile - one sling does many jobs
- Using two *Adjust-A-Links* on the same crane hook eliminates the need for expensive triples and quads
- Heat treated alloy steel construction for long sling life
- Yellow powder coating on master plate and hooks prevents rust - extends sling life

Saves Time

- More compact plate design fits larger hooks for easier rigging
- Less bulky than typical double adjustable chain slings
- High visibility yellow fittings make assembly easy to spot
- Easily adjustable to accommodate a wide range of applications
- No time wasted searching for just the right sling



LiftAlloy
Chain

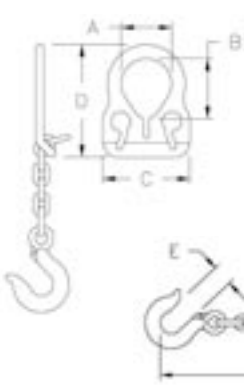

Note: To order latches on hooks, add an "L" to end of Part No.



Single



Double



Basket

* 1/2" size Master Link flame cut - not of new forged plate design - uses Grade 80 capacity ratings

Chain Size (in.)	1 st Rated Capacity * (lbs.)		Dimensions (in.)					6 ft. Length		10 ft. Length		14 ft. Length	
	Single @ 90°	Double @ 60°	Eye Width A	Eye Height B	Overall Width C	Overall Length D	Hook Opening E	Part No.	(lbs.)	Part No.	(lbs.)	Part No.	(lbs.)
7/32	2,700	4,700	2 3/16	2 11/16	3 15/16	5 1/8	15/16	30001G10	4.2	30002G10	6.2		
9/32	4,300	7,400	2 7/8	3 3/16	5 1/16	6 1/2	1 1/16	30003G10	7.5	30004G10	10.5		
3/8	8,800	15,200	3 3/4	4 1/8	6 3/4	8 11/16	1 9/16			30005G10	18.5	30006G10	24.5
1/2	12,000	20,800	4 3/8	4 3/8	9 3/4	12 3/4	2			30007	42	30008	52

* **WARNING** Do not exceed rated capacities. Sling capacity decreases as the angle from horizontal decreases. Adjust-A-Link Slings should not be used at angles of less than 45°. Refer to chain chart page 85 and Effect of Angle chart page 10.

HOOKS, MASTER LINKS, ETC.

Cradle Grab Eye Hook / Code G

Grade 80

Chain Size (in.)	Rated Capacity* (lbs.)	Dimensions (in.)						Weight Each (lbs.)
		B	D	E	I	L	M	
7/32	2,100	1.19	1.75	.36	1.19	.63	1.63	0.4
9/32	3,500	1.38	1.81	.36	1.19	.63	2.36	0.4
3/8	7,100	1.78	2.63	.45	1.75	.78	3.11	1.1
1/2	12,000	2.28	3.34	.59	1.88	1.03	3.94	2.3
5/8	18,100	2.75	4.08	.75	2.25	1.25	4.78	4.4
3/4	28,300	3.19	5.23	.88	2.88	1.44	6.25	8.8
7/8	34,200	3.75	5.69	1.00	3.00	1.75	6.50	10
1	47,700	4.31	7.00	1.19	3.88	1.88	8.09	21
1 1/4**	72,300	5.38	8.50	1.50	2.50	2.25	10.50	40

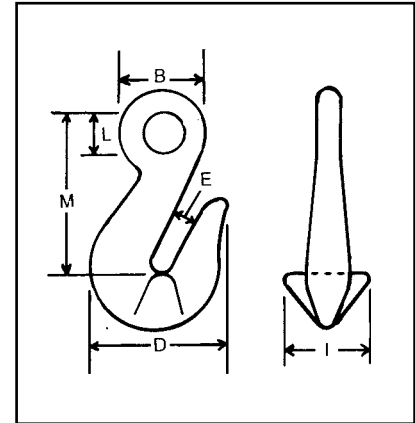

Grade 100

7/32	2,700	Use 9/32" Hook						
9/32	4,300	1.38	1.91	.36	1.06	.63	2.56	0.6
3/8	8,800	1.78	2.78	.47	1.38	.78	3.28	1.4
1/2	15,000	2.28	3.63	.59	1.81	1.03	4.22	3.1
5/8	22,600	2.75	4.08	.75	2.25	1.25	4.78	4.4
3/4	35,300	3.19	5.23	.88	2.88	1.44	6.25	8.8

** NOT cradle type

Note: Non-Cradle Grab Hooks are available upon request.

Foundry Hook / Code F

Grade 80

Chain Size (in.)	Rated Capacity* (lbs.)	Dimensions (in.)						Weight Each (lbs.)
		B	E	I	L	M	O	
9/32	3,500	1.56	2.50	1.00	.63	4.75	1.23	2.4
3/8	7,100	2.00	3.00	1.27	.75	5.75	1.50	4.5
1/2	12,000	2.50	3.50	1.50	1.00	6.88	1.75	7.1
5/8	18,100	3.00	4.00	1.81	1.25	8.06	2.03	12
3/4	28,300	3.50	4.50	2.20	1.50	9.25	2.56	20
7/8	34,200	4.00	5.00	2.25	1.75	10.38	2.78	26
1	47,700	4.50	5.50	2.59	2.13	11.56	3.03	37
1 1/4	72,300	5.13	6.00	3.17	2.38	12.88	3.81	58

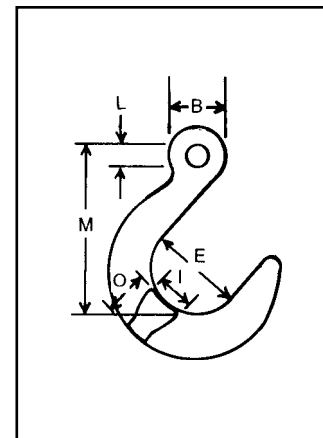

Grade 100

9/32	5,700	1.56	2.50	1.00	.63	4.75	1.23	2.4
3/8	8,800	2.00	3.00	1.27	.75	5.75	1.50	4.5
1/2	15,000	2.50	3.50	1.50	1.00	6.88	1.75	7.1
5/8	22,600	3.00	4.00	1.81	1.25	8.06	2.03	12
3/4	35,300	3.50	4.50	2.20	1.50	9.25	2.56	20

*

WARNING

Do not exceed rated capacities. Sling capacity decreases as the angle from horizontal decreases. Slings should not be used at angles of less than 30°. Refer to chain chart page 85 and Effect of Angle chart page 10.

HOOKS, MASTER LINKS, ETC.

Lodelok Eye Hooks

Grade 80

Chain Size (in.)	Rated Capacity* (lbs.)	Dimensions (in.)					Weight Each (lbs.)
		C	D	E	F	J	
9/32	4,300	5.37	.88	3.77	1.64	.91	2.5
3/8	8,800	6.65	1.07	4.76	2.27	1.14	4.6
1/2	15,000	8.79	1.58	6.26	2.91	1.46	10.0
5/8	22,600	10.36	1.97	7.37	3.20	1.81	16.0

Design factor @ 4:1

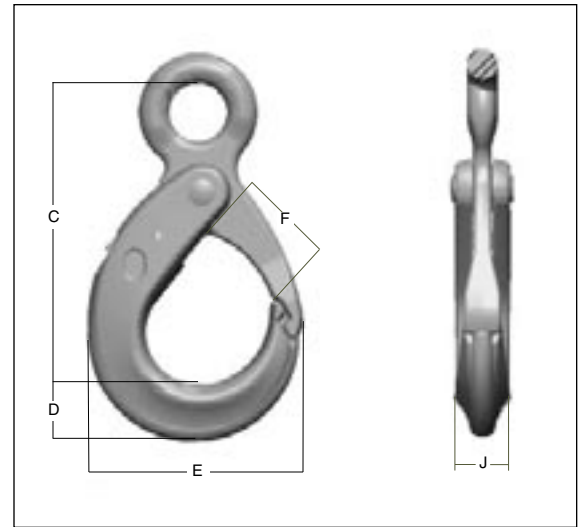

Cradle Grab Clevis Hook / Code G

Grade 80

Chain Size (in.)	Rated Capacity* (lbs.)	Dimensions (in.)				Weight Each (lbs.)
		D	E	T	M	
9/32	3,500	1.78	.36	1.19	1.63	0.5
3/8	7,100	2.56	.47	1.75	2.11	1.2
1/2	12,000	3.25	.59	2.13	2.88	2.4
5/8	18,100	4.08	.75	2.50	3.56	4.2
3/4	28,300	5.23	.88	2.88	5.50	9.6

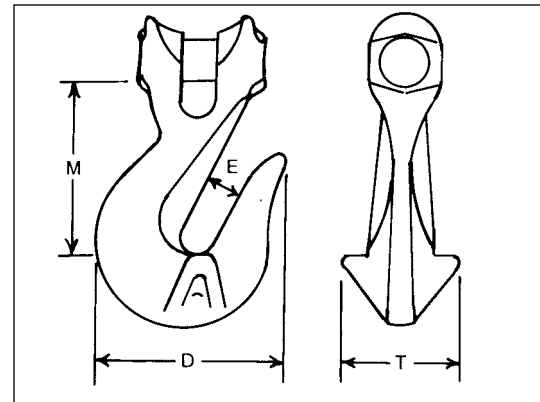

LiftAlloy Chain

Chain Sling Clevis Hook with Optional Latch / Code S

Grade 80

Chain Size (in.)	Rated Capacity* (lbs.)	Dimensions (in.)				Weight Each (lbs.)
		I	M	P	R	
9/32	3,500	.73	3.44	1.05	1.06	0.8
3/8	7,100	.95	4.47	1.28	1.31	2.0
1/2	12,000	1.17	5.27	1.66	1.56	4.5
5/8	18,100	1.44	6.08	2.19	1.75	6.5
3/4	28,300	1.69	7.34	2.56	2.19	12

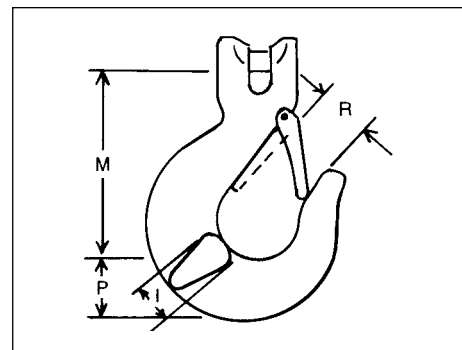

HOOKS, MASTER LINKS, ETC.

Oblong Master Link / Code O

Link Size * (in.)			Type & Size of Chain Sling on which used				Weight Each (lbs.)
Diameter Material A	Inside Width B	Inside Length C	Single	Double	Triple	Quad	
13/32	1 1/2	3	7/32	7/32	-	-	0.3
1/2	2 1/2	5	9/32	9/32	7/32	7/32	0.8
3/4	3	6	3/8	3/8	9/32	9/32	2.1
1	4	8	1/2 or 5/8	1/2	3/8	3/8	4.6
1 1/4	4 3/8	8 3/4	3/4	5/8	1/2	1/2	9.2
1 1/2	5 1/4	10 1/2	7/8	3/4	5/8	5/8	16
1 3/4	6	12	1	7/8	3/4	3/4	25
2	7	14	1 1/4	1	7/8	7/8	37
2 1/4	8	16	-	1 1/4	1	1	54
2 3/4	9	16	-	-	1 1/4	1 1/4	85

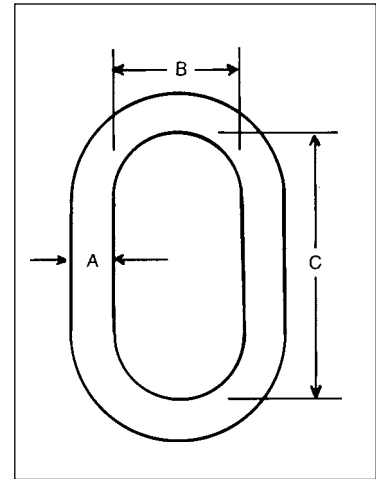

* If sub-assemblies are used, inside dimensions may be reduced. Contact Lift-All if critical.

LiftAlloy Chain

Chain Sling Eye Hook with Optional Latch / Code S

Grade 80

Chain Size (in.)	Rated Capacity* (lbs.)	Dimensions (in.)							Weight Each (lbs.)
		B	E	I	L	M	P	R	
7/32	2,100	-	1.25	.78	.75	3.06	.86	1.11	0.7
9/32	3,500	1.62	1.19	.73	.75	3.75	1.05	1.06	1.1
3/8	7,100	2.06	1.44	.95	.94	4.78	1.28	1.31	1.9
1/2	12,000	2.63	1.78	1.17	1.13	5.69	1.66	1.56	4.5
5/8	18,100	3.06	2.03	1.44	1.31	6.50	2.19	1.75	7.3
3/4	28,300	3.50	2.50	1.69	1.50	7.81	2.51	2.19	11
7/8	34,200	3.88	2.78	1.94	1.69	8.75	2.84	2.38	18
1	47,700	4.31	3.13	2.14	1.88	9.88	3.09	2.78	23
1 1/4	72,300	5.31	3.88	2.62	2.31	11.50	3.89	3.41	36

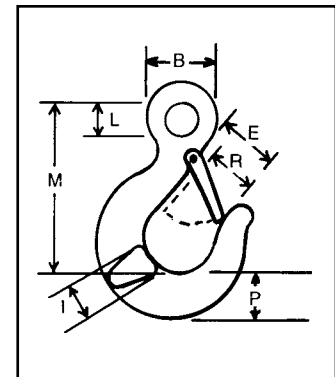

Grade 100

7/32	2,700	Use 9/32" Hook							
9/32	5,700	1.62	1.19	.73	.75	3.75	1.05	1.06	1.1
3/8	8,800	2.06	1.44	.95	.94	4.78	1.28	1.31	1.9
1/2	15,000	2.63	1.78	1.17	1.13	5.69	1.66	1.56	4.5
5/8	22,600	3.06	2.03	1.44	1.31	6.50	2.19	1.75	7.3
3/4	35,300	3.50	2.50	1.69	1.50	7.81	2.51	2.19	11

Note: When ordering, specify latch if desired.

HOOKS, MASTER LINKS, ETC.

Mechanical Coupling Links

Grade 80

Chain Size (in.)	Rated Capacity* (lbs.)	Dimensions (in.)				Weight Each (lbs.)
		A	B	C	E	
7/32	2,100	.25	1.41	.49	.41	0.12
9/32	3,500	.31	1.81	.63	.50	0.23
3/8	7,100	.50	2.41	.83	.75	0.65
1/2	12,000	.69	3.38	1.22	1.00	1.5
5/8	18,100	.81	4.06	1.50	1.25	2.6
3/4	28,300	.94	4.78	1.80	1.50	3.8
7/8	34,200	1.05	5.13	1.91	1.75	6.3
1	47,700	1.25	5.75	2.19	2.00	9.3
1 1/4	72,300	1.53	6.81	2.63	2.25	17

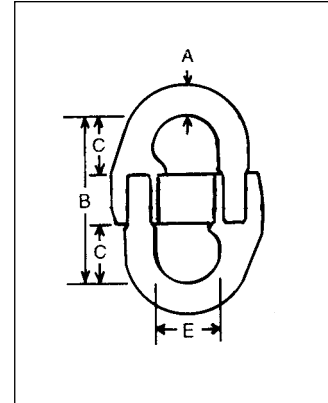
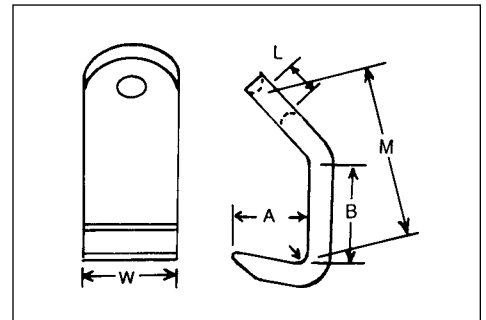

Plate Hook

Chain Size (in.)	Rated Capacity* (lbs.)	Dimensions (in.)					Weight Each (lbs.)
		A	B	L	M	W	
9/32	4,200	2.00	1.75	1.00	3.68	2.50	2.8
3/8	7,400	2.63	3.00	1.12	6.38	2.75	5.7
1/2	13,000	3.50	4.00	1.50	7.37	3.50	13
5/8	20,400	4.38	5.00	1.88	9.25	5.00	27
3/4	30,000	5.18	6.00	2.25	10.88	5.75	42
7/8	40,000	6.00	7.00	2.63	13.68	6.00	65



LiftAlloy Chain

* Ratings are per hook
Do not use plate hooks at angles other than 60° from horizontal.
Do not attempt to lift using only one plate hook.

S Hook

Stock Dia. (in.)	Rated Capacity* (lbs.)	Dimensions (in.)				Weight Each (lbs.)
		A	B	F	R	
9/32	210	4 1/2	1 1/8	1 1/8	9/16	0.15
3/8	410	6	1 1/2	1 1/2	3/4	0.35
1/2	870	7 1/2	2	2	1	0.82
5/8	1,120	9	2 1/2	2 1/2	1 1/4	1.6
3/4	1,730	10 1/2	3	3	1 1/2	2.6
7/8	2,370	12	3 1/2	3 1/2	1 3/4	4.2
1	2,920	13	4	4	2	6.0
1 5/32	3,150	15	4 1/2	4 1/2	2 1/4	9.3
1 1/4	4,450	16	5	5	2 1/2	12
1 3/8	6,100	17	5 1/2	5 1/2	2 3/4	15
1 1/2	6,250	18	6	6	3	20

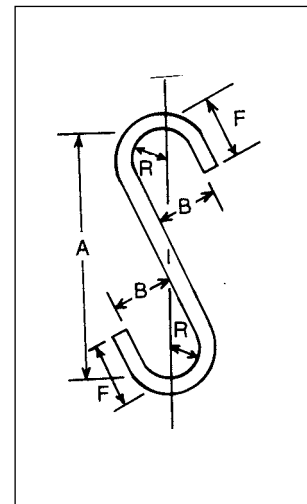

See page 116 for J-Hooks and Custom Engineered Lifting Devices.

*

⚠ WARNING

Do not exceed rated capacities. Sling capacity decreases as the angle from horizontal decreases. Slings should not be used at angles of less than 30°. Refer to chain chart page 85 and Effect of Angle chart page 10.

CHAIN

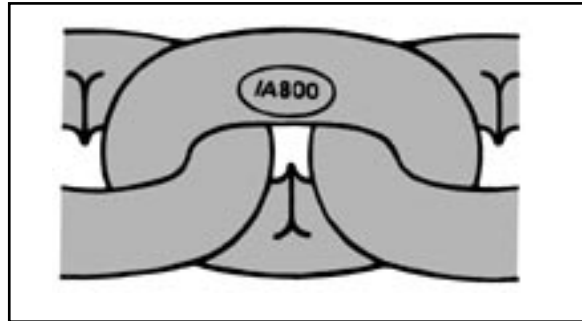

LiftAlloy Grade 80 Welded Alloy Chain

- Primarily used for overhead lifting slings
- Proof tested
- Black finish

Welded Carbon Chain

- Grade 30 Proof Coil available as self colored, zinc plated or hot galvanized
- Grade 43 High Test available as bright finish, zinc plated or hot galvanized
- Grade 70 Binding (transport) is furnished with a gold finish as standard

Alloy Chain

Chain Size (in.)	Grade 80	
	Rated Capacity* (lbs.)	Weight Per CFT. (lbs.)
7/32	2,100	45
9/32	3,500	74
3/8	7,100	146
1/2	12,000	258
5/8	18,100	387
3/4	28,300	622
7/8	34,200	776
1	47,700	995
1 1/4	72,300	1571

Carbon Chain

Chain Size (in.)	Grade 30		Grade 43		Grade 70	
	Rated Capacity* (lbs.)	Weight Per CFT. (lbs.)	Rated Capacity* (lbs.)	Weight Per CFT. (lbs.)	Rated Capacity* (lbs.)	Weight Per CFT. (lbs.)
3/16	800	38	-	-	-	-
1/4	1,300	66	2,600	71	3,150	74
5/16	1,900	98	3,900	98	4,700	100
3/8	2,650	144	5,400	144	6,600	156
1/2	4,500	278	9,200	278	11,300	259
5/8	6,900	422	13,000	422	-	-
3/4	10,600	628	20,200	606	-	-

Note: Grade 30 Proof Coil, Grade 43 High Test and Grade 70 Binding (transport) tiedown chain and their fittings are not recommended for lifting or hoisting per ASME B30.9.

* **⚠ WARNING**

Do not exceed rated capacities. Sling capacity decreases as the angle from horizontal decreases. Slings should not be used at angles of less than 30°. Refer to chain chart page 85 and Effect of Angle chart page 10.