

GANTRY SLING RACK

A great addition to any manufacturing or industrial facility.

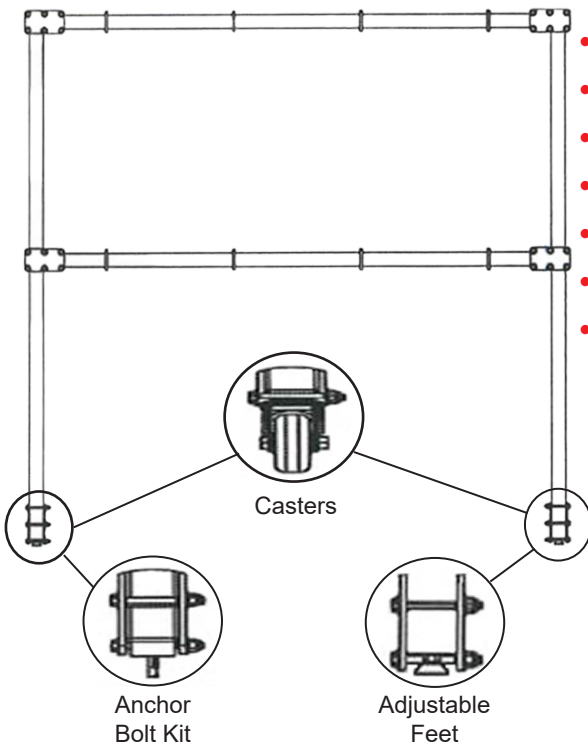
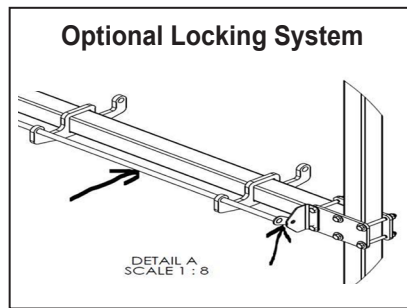
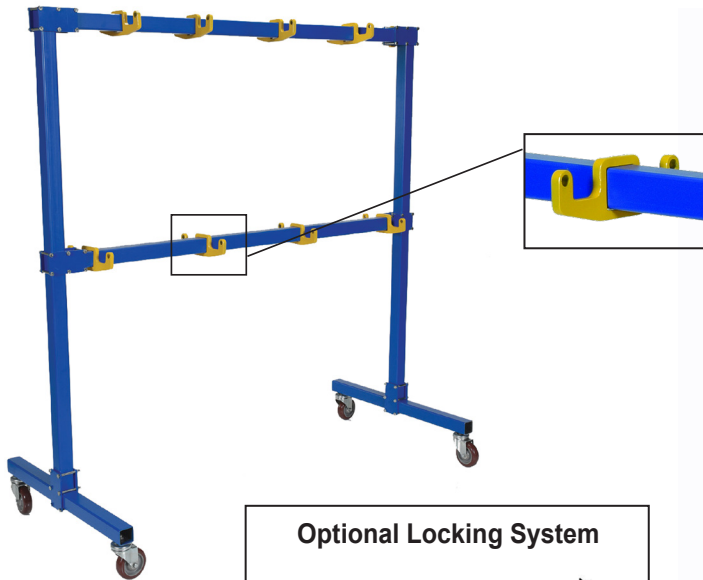

- Strong steel construction.
- Blue powder-coated toughness.
- Adjustable double hooks - max capacity 150-lbs.
- Eight double hooks are standard.
- Comes with adj. feet, casters, and anchor bolt kit.
- Capacity using adj. feet and anchor bolt kit: 2,000-lbs.
- Capacity using casters: 1,200-lbs.
- Optional: extra hooks and hook lock.

Part Number	Description	Weight
SLR-UM-6	Universal Sling Rack	164-lbs.
SLR-LS	Locking System	24-lbs.
SLR-HK	Additional Hooks (ea.)	7.94-lbs.

General Information
Web Slings
Round Slings
Sling Protection
Wire Rope
Chain Slings
Rigging Hardware
Mesh Slings
Load Huggers
Tow Products
Lift-All Hoists
Hoist Rings
Plate Clamps
Lifting Devices