

EFFECT OF SLING ANGLE

Using slings at an angle **can become deadly** if that angle is not taken into consideration when selecting the sling to be used. The tension on each leg of the sling is increased as the angle of lift, from horizontal, decreases. It is most desirable for a sling to have a larger angle of lift, approaching 90°. Lifts with angles of less than 30° from horizontal are not recommended. If you can measure the angle of lift or the length and height of the sling as rigged, you can determine the properly rated sling for your lift. The Increased Tension method provides the increased tension as a function of the sling angle. Alternatively, the sling Reduced Capacity method may be used to determine reduced lift capacity for any angle.

INCREASED TENSION

Determine capacity of sling needed

- Determine the load weight (LW).
- Calculate the tension factor (TF):
 - Determine the sling angle as measured from the horizontal, and the corresponding tension factor (TF) from the effect of angle chart.

OR

- Length* (L) divided by height* (H)
- Determine the share of the load applied to each sling leg (LW).
 - Multiply (LW) by (TF) to determine the sling leg tension. The capacity of the selected sling or sling leg must meet the calculated tension value.

* Measured from a common horizontal plane to the hoisting hook.

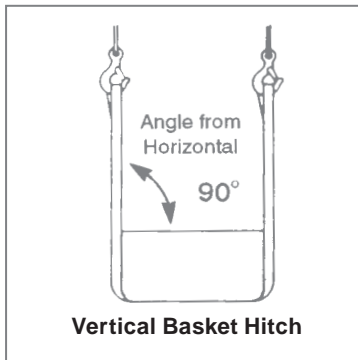
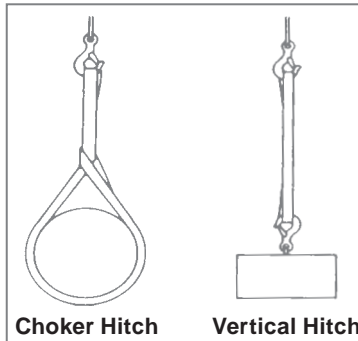

REDUCED CAPACITY

Calculate rating of each sling rigged at this angle

- Calculate the reduction factor (RF).
 - Using the angle from horizontal, read across the angle chart to the corresponding number in the Reduction Factor column.

OR

- Divide sling height* (H) by sling length* (L).
- Reduction factor (RF) x the sling's rated capacity for the type hitch that will be used = sling's reduced rating.

* Measured from a common horizontal plane to the hoisting hook.

INCREASED TENSION

LW = 500 lbs. LW = 500 lbs.

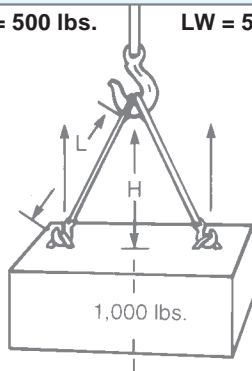

EXAMPLE

Load weight: 1,000 lbs.
 Rigging: Two slings in vertical hitch
 Lifting weight (LW) per sling: 500 lbs.
 Measured sling length (L): 10 ft.
 Measured Sling Height (H): 5 ft.
 Tension factor (TF): $10(L) \div 5(H) = 2.0$
 Minimum vertical rated capacity required for this lift:
 $500(LW) \times 2.0(TF) = 1,000 \text{ lbs. per sling}$

EFFECT OF ANGLE CHART

Tension Factor (TF)	Angle From Horizontal	Reduction Factor (RF)
1.000	90°	1.000
1.004	85°	0.996
1.015	80°	0.985
1.035	75°	0.966
1.064	70°	0.940
1.104	65°	0.906
1.155	60°	0.866
1.221	55°	0.819
1.305	50°	0.766
1.414	45°	0.707
1.555	40°	0.643
1.742	35°	0.574
2.000	30°	0.500

Sling capacity decreases as the angle from horizontal decreases.

Sling angles of less than 30° are not recommended.

REDUCED CAPACITY

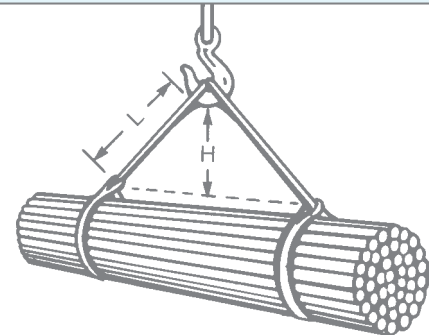

EXAMPLE

Vertical choker rating of ea. sling: 6,000 lbs.
 Measured sling length (L): 6 ft.
 Measured sling height (H): 4 ft.
 Reduction factor (RF): $4(H) \div 6(L) = .667$
 Reduced sling rating in this configuration:
 $667(RF) \times 6,000 \text{ lbs.} = 4,000 \text{ lbs. of lifting capacity per sling}$