

## GANTRY SLING RACK

A great addition to any manufacturing or industrial facility.

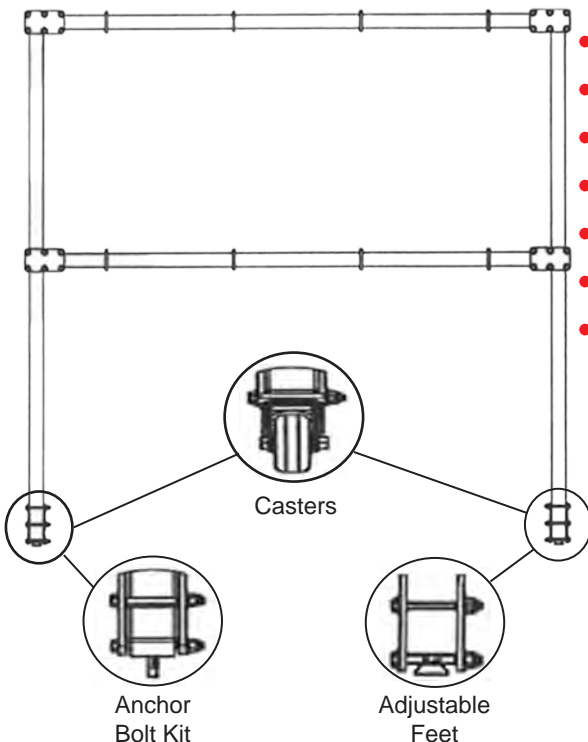
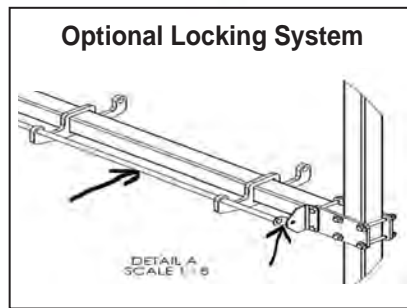
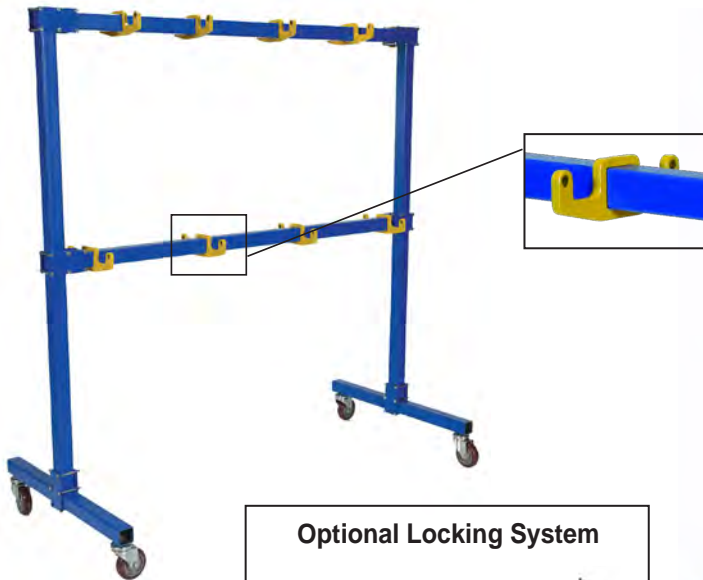

- Strong steel construction.
- Blue powder-coated toughness.
- Adjustable double hooks - max capacity 150-lbs.
- Eight double hooks are standard.
- Comes with adj. feet, casters, and anchor bolt kit.
- Capacity using adj. feet and anchor bolt kit: 2,000-lbs.
- Capacity using casters: 1,200-lbs.
- Optional: extra hooks and hook lock.

Part Number	Description	Weight
SLR-UM-6	Universal Sling Rack	164-lbs.
SLR-LS	Locking System	24-lbs.
SLR-HK	Extra Set Double Hooks	15-lbs.

General Information  
 Web Slings  
 Round Slings  
 Sling Protection  
 Wire Rope  
 Chain Slings  
 Rigging Hardware  
 Mesh Slings  
 Load Huggers  
 Tow Products  
 Lift-All Hoists  
 Hoist Rings  
 Plate Clamps  
 Lifting Devices