

STEELFLEX™ ROUNDSLINGS

THE STEEL SLING
WITH THE FABRIC FEEL

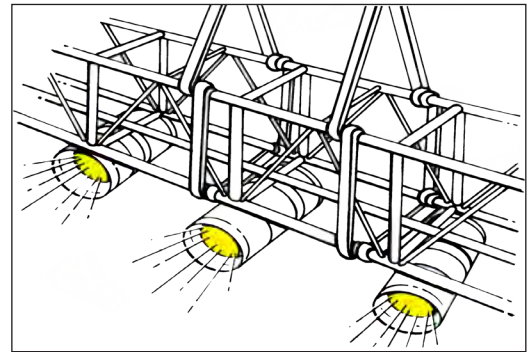

Designed for suspension applications

With safety being of the utmost importance in overhead suspension, *Lift-All's SteelFlex* roundslings combine flexibility, strength and heat resistance (400°F) with the soft feel of fabric to meet your most demanding suspension requirements.

SteelFlex roundslings feature steel galvanized aircraft cable wound in an endless configuration. This wire core is encased in a black double-wall, polyester jacket. A unique inspection window allows for easy inspection of the core for broken wires and corrosion. The result is a highly flexible, easy to use sling that complies with all of the current rigging codes. Stretch at rated capacity is approximately 1%.

Features and Benefits

- Black cover for stage rigging applications.
- No backup rigging required.
- Engineered window allows for core inspection.
- Superior flexibility makes rigging easy.
- Conforms to the load to grip securely.
- Superior cut resistance.

How To Measure

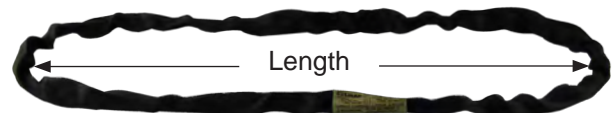

| Part Numbers | Weight per Foot (lbs.) | Rated Capacity (lbs.) | | | Minimum Hardware Dia. (in.) |
|---------------|------------------------|-----------------------|--------|--------|-----------------------------|
| | | Vertical | Choker | Basket | |
| GACEN40X18IN | 0.60 | 3,600 | 3,000 | 7,200 | .625 |
| GACEN40X2 | | | | | |
| GACEN60CX18IN | 0.75 | 5,300 | 4,200 | 10,600 | .625 |
| GACEN60CX2 | | | | | |
| GACEN60X3 | | | | | |
| GACEN60X4 | | | | | |
| GACEN60X5 | | | | | |
| GACEN60X6 | | | | | |
| GACEN60X7 | | | | | |
| GACEN60X8 | | | | | |
| GACEN60X9 | | | | | |
| GACEN60X10 | | | | | |
| GACEN60X11 | | | | | |
| GACEN60X12 | | | | | |

400°F Temperature Rating
NO Wire Rope Backup Needed
Core Inspection Window Standard

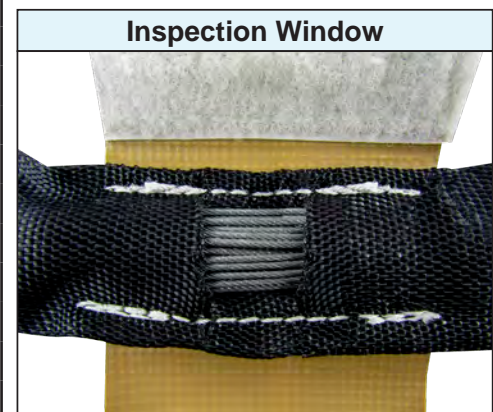

1. Maximum length for *SteelFlex* is 12-ft.
2. Sling lengths under 3' use a modified construction and do not have a seamless cover.